

Belt driven guided linear unit

Linearantrieb mit Zahnriemen und integrierter Kugelumlaufführung
 Attuatori lineari a cinghia e guida a ricircolo di sfere

TECHNICAL DATA | TECHNISCHE DATEN | DATI TECNICI

Size - Baugröße - Taglia		105x105
Max. speed - Max. Geschwindigkeit - Velocità max	m/s	3
Max. stroke length - Max. Hub - Corsa max	mm	6700
Min. stroke length - Min. Hub - Corsa min	mm	100
Pulley drive ratio - Hub pro Umdrehung - Corsa/giro puleggia	mm	210
Number of teeth of pulley - Zähne der Riemenscheibe - nr. denti puleggia		21
Teeth belt with Steel Reinforced Polyurethane ATL 10 profile clearance 0, width 32 mm ATL 5-Profil Riemen 32 mm Breite - 10mm Achsabstand Tipo di cinghia profilo ATL passo 10 larghezza 32 mm		
Max rpm - Max. Drehzahl der Antriebswelle - Max nr. di giri in ingresso	rpm	850
Base weight - Gewicht bei 0mm Hub - Peso corsa 0 mm	Kg	12,5
Add for 100 mm of stroke - Gewicht bei 100mm Hub - Peso corsa 100 mm	Kg	1,5
Max. load* - Max. Belastung* - Carico max*	Fx	N 2750
	Fy	N 7500
	Fz	N 7500
Moments* - Max. Belastungsmoment* - Momenti max*	Mx	Nm 120
	My	Nm 700
	Mz	Nm 700
Inertia moment Aluminum profile - Flächenträgheitsmoment - Momento d'inerzia profilo	Ix	cm4 440
	Iy	cm4 535
Repeatability - Wiederholgenauigkeit - Ripetibilità	mm	± 0,05
Max. radial load on input shaft - Max. axiallylasten an der Antriebswelle Carico assiale max all'albero motore	N	400
No load torque - Leerlaufmoment - Coppia resistente	Nm	>0,8

* Max values for dynamic conditions. Please refer to the following formula when combined loads are applied.

* Für die Ermittlung der maximalen dynamischen Tragzahlen bei kombinierten Kraftangriffspunkten, nutzen Sie bitte die nebenstehende Berechnungsformel.

* Valori massimi in condizioni dinamiche. In presenza di carichi combinati riferirsi alla formula per la verifica dei carichi massimi da applicare.

$$\frac{F_{yA}}{F_y} + \frac{F_{zA}}{F_z} + \frac{M_{xA}}{M_x} + \frac{M_{yA}}{M_y} + \frac{M_{zA}}{M_z} \leq 1$$

The A letters show the calculated value.
 Der A Parameter entspricht dem errechneten Wert.
 La lettera A indica i valori complessivi calcolati

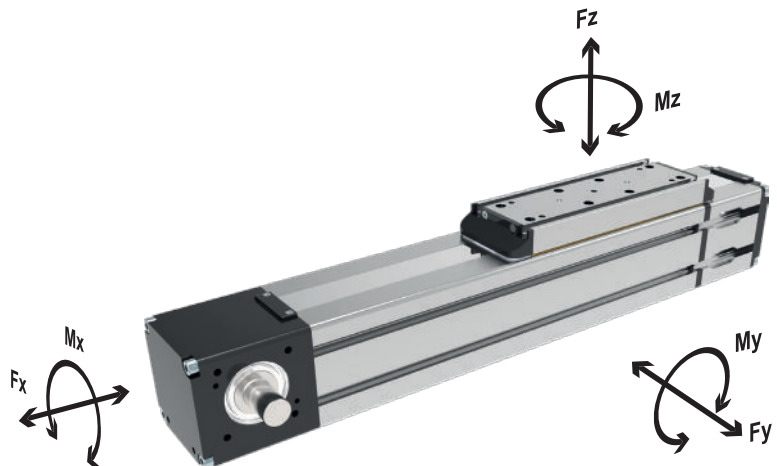

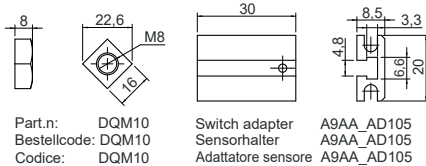
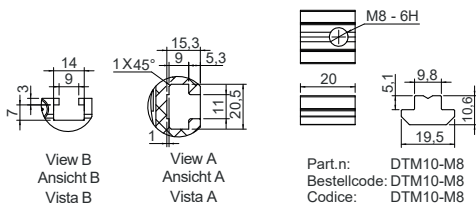
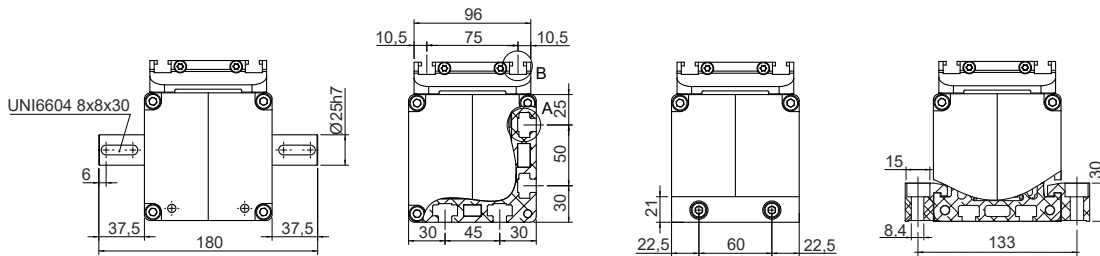
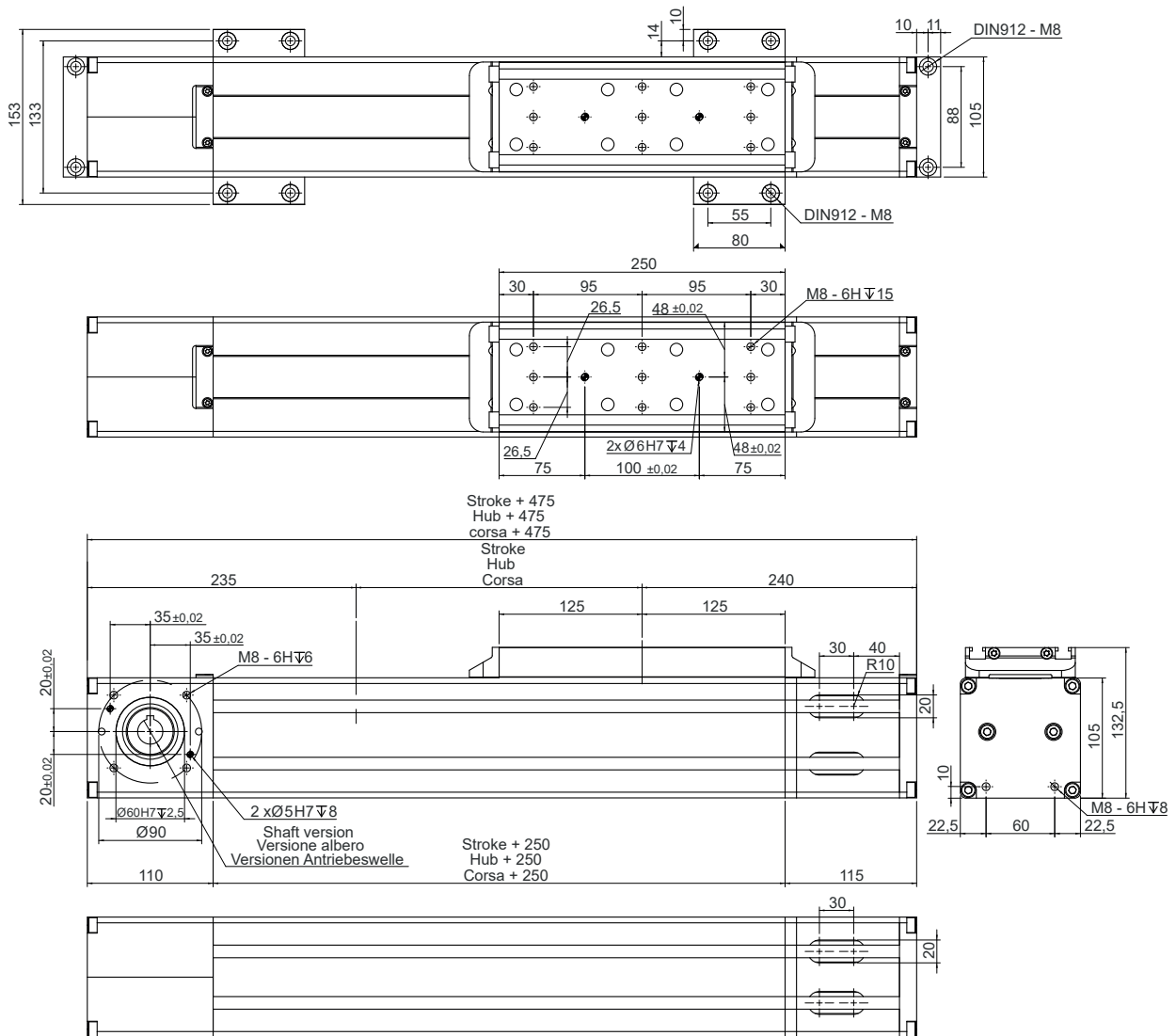

Left mount M25L
Antriebswelle links M25L
Lato sinistro M25L



Dual mount D25
Doppelwelle D25
Doppio albero D25

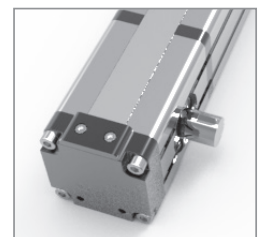

Right mount M25R
Antriebswelle rechts M25R
Lato destro M25R

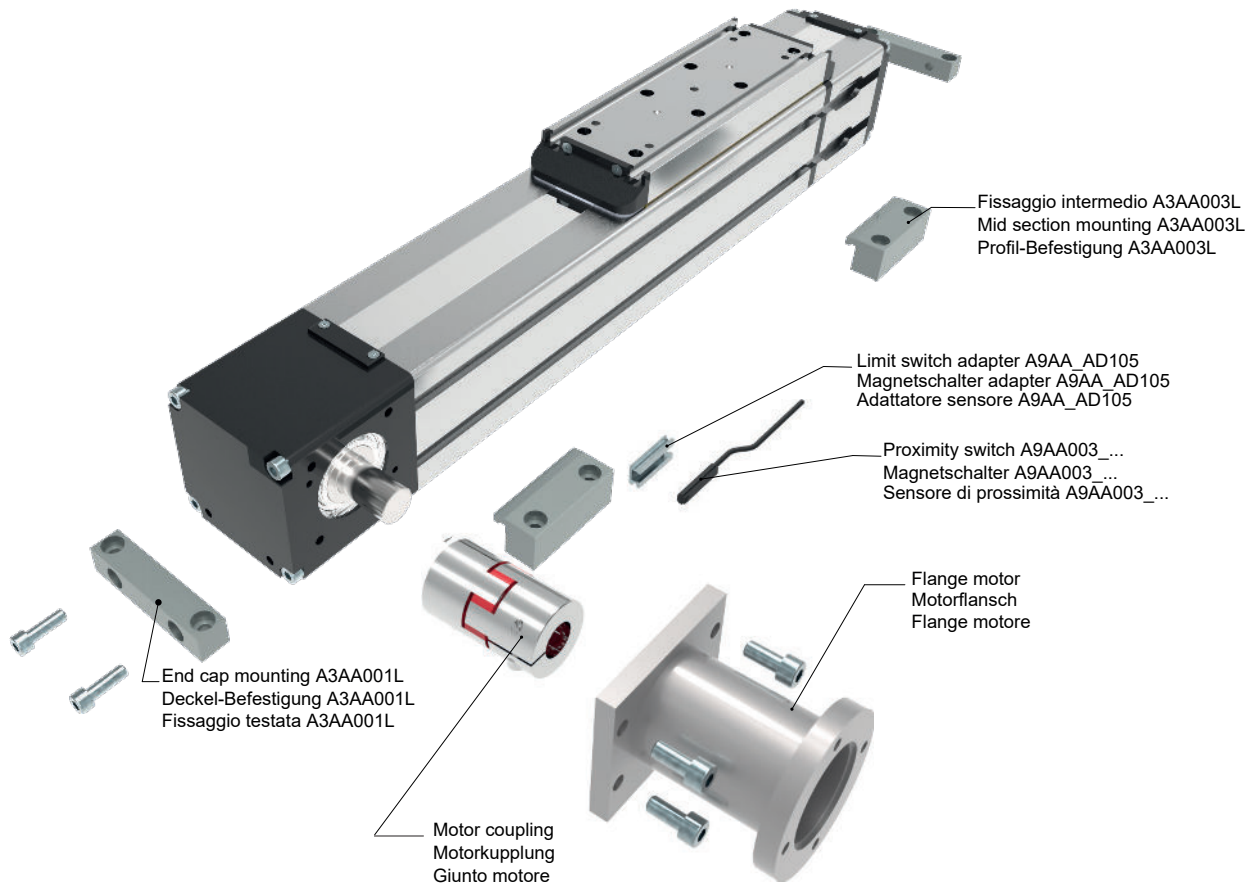

ORDERING INFORMATION | Bestallangaben Baureihe | Codici per l'ordinazione

¹Proximity switch A9AA003_... | ¹Magnetschalter A9AA003_... | ¹Sensore di prossimità A9AA003_...

Part nr. Ident nr. Cod.	Cable Kabel Cavo	Output Ausgangfunktion Uscita
A9AA003_01	with 2 mt cable mit 2 mt kabel con cavo 2 mt	PNP
A9AA003_02	with 2 mt cable mit 2 mt kabel con cavo 2 mt	NPN
A9AA003_03	200 mm with M8 plug in mit 200 mm kabel und M8 stecker 200 mm conn. M8	PNP
A9AA003_04	200 mm with M8 plug in mit 200 mm kabel und M8 stecker 200 mm conn. M8	NPN
A9AA003_NC	with 2 mt cable mit 2 mt kabel con cavo 2 mt	NC

MTB105 - 0900 - F22

Shaft | Versionen Antriebeswelle | Versione Albero

Series and size 105x105

Serie und Baugöße 105x105
Serie e taglia 105x105

Stroke mm

Hub mm
Corsa mm

- F22: Female shaft Ø22 mm with keyshaft
Hohlwelle mit Ø22 mm und Passfeder
Albero femmina Ø22 mm con chiavetta
- F25: Female shaft Ø25 mm with keyshaft
Hohlwelle mit Ø25 mm und Passfeder
Albero femmina Ø25 mm con chiavetta
- M25L: Male shaft Ø25 mm mount left
Außenwelle mit Ø25 mm und Wellenposition rechts
Albero maschio uscita Ø16 mm lato sinistro
- M25R: Male shaft Ø25 mm mount right
Außenwelle mit Ø25 mm und Wellenposition links
Albero maschio uscita Ø25 mm lato destro
- D25: Double male shaft Ø25 mm
Doppelwelle mit Ø25 mm
Doppio albero maschio Ø25 mm