

Screw driven guided linear unit

Linearantrieb mit Rundspindel und integrierter Kugelumlaufführung
 Attuatori lineari a vite e guida a ricircolo di sfere

TECHNICAL DATA | TECHNISCHE DATEN | DATI TECNICI

Size - Baugröße - Taglia			42x45
Max. speed* - Max. Geschwindigkeit* - Velocità max*	m/s		0,75*
Max. stroke length - Max. Hub - Corsa max	mm		1000
Min. stroke length - Min. Hub - Corsa min	mm	100	100
Pitch - Spindelsteigung - Passo vite	mm	5	10
Screw diameter - Spindeldurchmesser - Diametro vite	mm		12
Base weight - Gewicht bei 0mm Hub - Peso corsa 0 mm	Kg		1,8
Add for 100 mm of stroke - Gewicht bei 100mm Hub - Peso corsa 100 mm	Kg		0,45
Max. load** - Max. Belastung** - Carico max**	Fx	N	980
	Fy	N	1250
	Fz	N	1250
Moments* - Max. Belastungsmoment* - Momenti max*	Mx	Nm	20
	My	Nm	45
	Mz	Nm	45
Inertia moment profile - Flächenträgheitmoment - Momento d'inerzia profilo	Ix	cm ⁴	15,1
Inertia moment profile - Flächenträgheitmoment - Momento d'inerzia profilo	Iy	cm ⁴	15,5
Repeatability - Wiederholgenauigkeit - Ripetibilità	mm		± 0,02
Screw class ***- klasse Kugelgewinde*** - Classe vite***			T7
No load torque - Leerlaufmoment - Coppia resistente	Nm	0,2	0,15

* It depends from stroke and the spindle lead
 * In Abhängigkeit von Hub und Spindelsteigung
 * Valore indicativo, dipende dalla corsa e dal passo vite

** Max values for dynamic conditions. Please refer to the following formula when combined loads are applied.

** Für die Ermittlung der maximalen dynamischen Tragzahlen bei kombinierten Kraftangriffspunkten, nutzen Sie bitte die nebenstehende Berechnungsformel.

** Valori massimi in condizioni dinamiche. In presenza di carichi combinati riferirsi alla formula per la verifica dei carichi massimi da applicare.

$$\frac{F_{yA}}{F_y} + \frac{F_{zA}}{F_z} + \frac{M_{xA}}{M_x} + \frac{M_{yA}}{M_y} + \frac{M_{zA}}{M_z} \leq 1$$

The A letters show the calculated value.
 Der A Parameter entspricht dem errechneten Wert.
 La lettera A indica i valori complessivi calcolati

*** Different types of screws are available, rolled or ground with different tolerances and trapezoidal screws.

*** Verschiedene Spindelvarianten sind verfügbar. Kugelrollspindeln geschliffen in verschiedenen Genauigkeitsklassen sowie Trapezspindeln.

*** Tipologie di viti disponibili: rullate, rettifiche con diversi classi di precisione e trapezoidali.

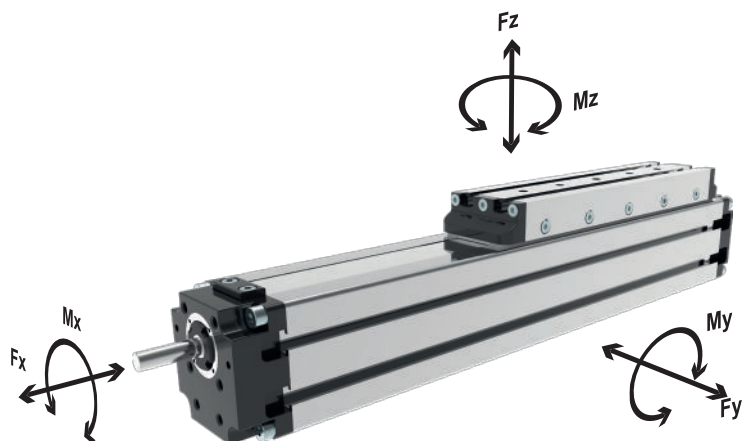

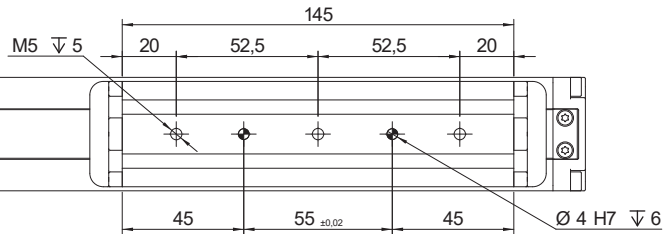
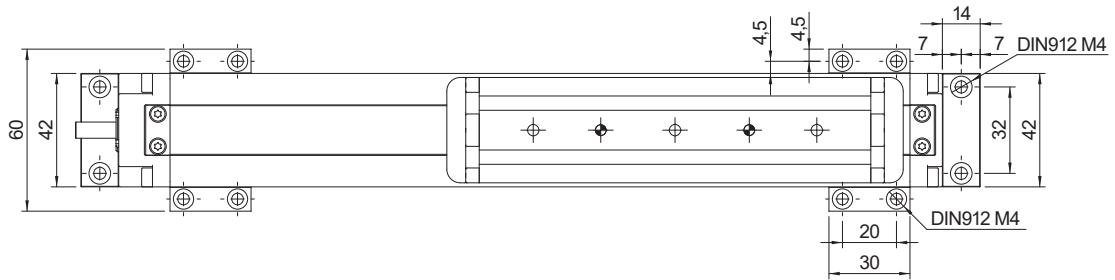

Stroke + 205
Hub + 205
Corsa + 205

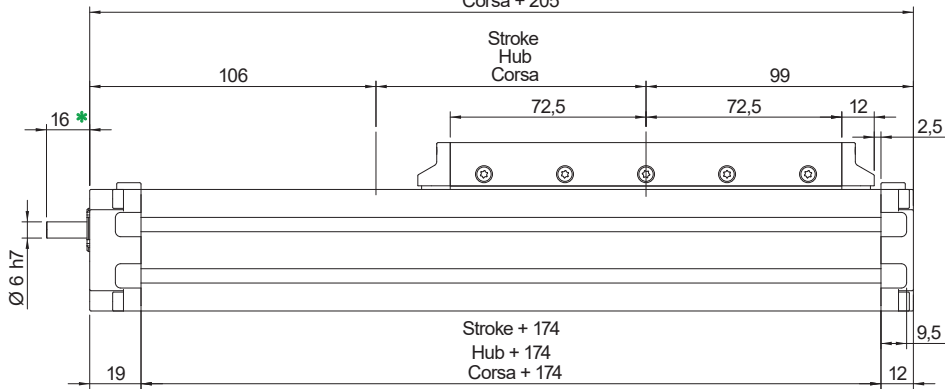

Stroke + 174
Hub + 174
Corsa + 174

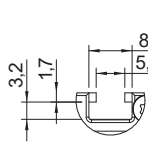
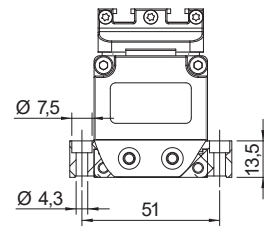
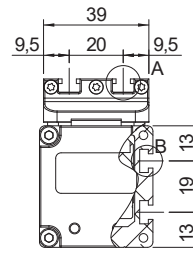
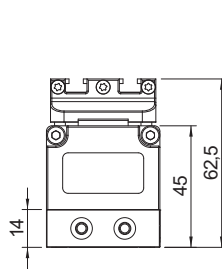
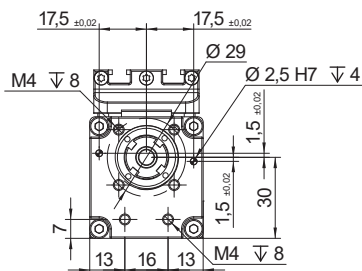

View A
Ansicht A
Vista A

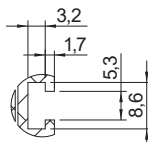

View B
Ansicht B
Vista B

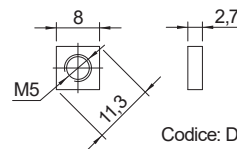

Codice: DQM05-01
Part. n: DQM05-01
Bestellcode: DQM05-01

* Measure likely to change according to customer request
Messen sich wahrscheinlich ändern nach Kundenwunsch
Misura suscettibile di modifica su richiesta del cliente

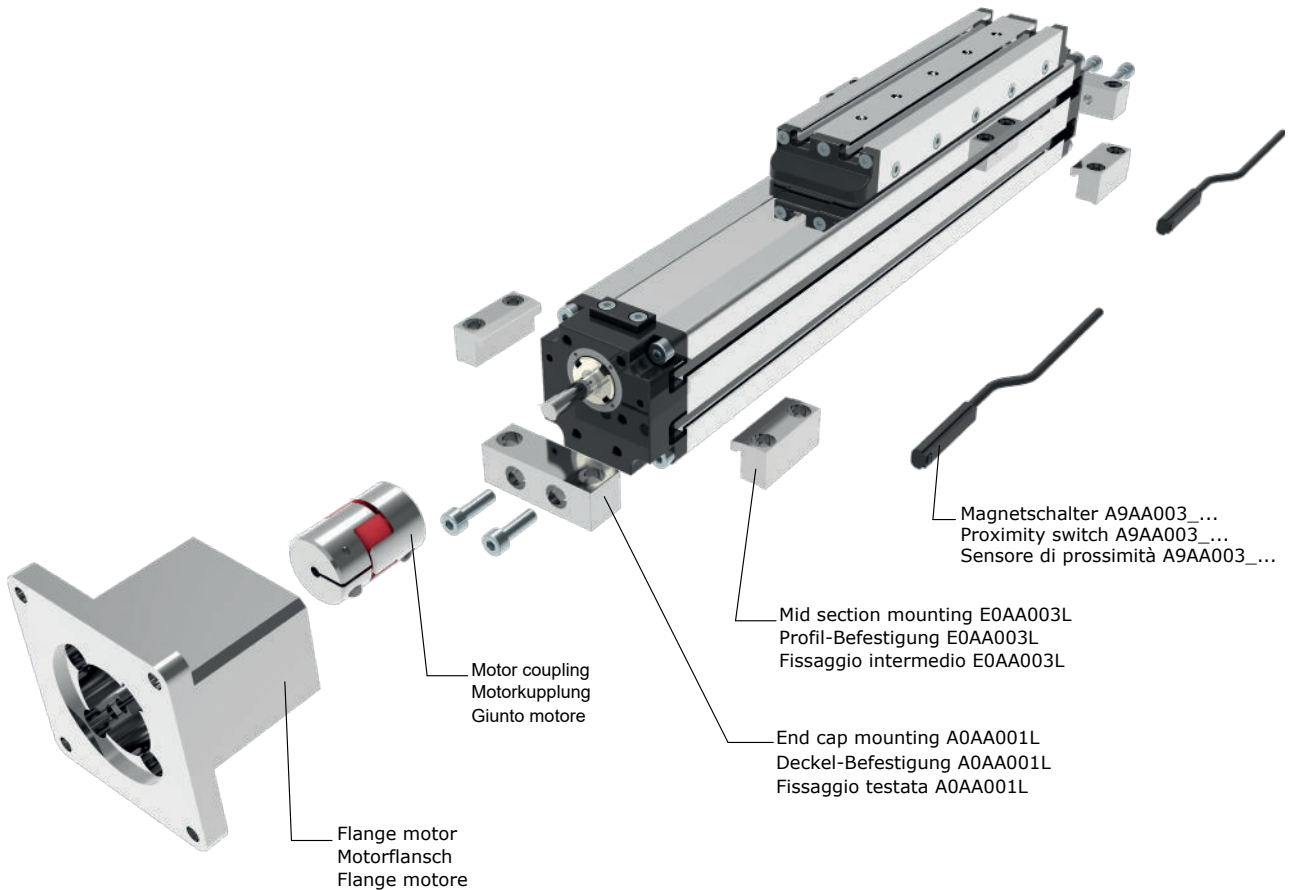

ORDERING INFORMATION | Bestallangaben Baureihe | Codici per l'ordinazione

¹Proximity switch A9AA003_... | ¹Magnetschalter A9AA003_... | ¹Sensore di prossimità A9AA003_...

Part nr. Ident nr. Cod.	Cable Kabel Cavo	Output Ausgangfunktion Uscita
A9AA003_01	with 2 mt cable mit 2 mt kabel con cavo 2 mt	PNP
A9AA003_02	with 2 mt cable mit 2 mt kabel con cavo 2 mt	NPN
A9AA003_03	200 mm with M8 plug in mit 200 mm kabel und M8 stecker 200 mm conn. M8	PNP
A9AA003_04	200 mm with M8 plug in mit 200 mm kabel und M8 stecker 200 mm conn. M8	NPN
A9AA003_NC	with 2 mt cable mit 2 mt kabel con cavo 2 mt	NC

MTV42-0500-12 05-R A

Series MTV
Serie MTV
Serie MTV

Size 42x45
Baugröße 42x45
Grandezza 42x45

Stroke mm
Hub mm
Corsa mm

Screw diam.
Durchmesser Spindle
Dim. Vite Ø12 mm

Screw pitch
Spindelsteigung
Passo vite
05 = 5 mm
10 = 10 mm

Shaft | Versionen Antriebswelle | Versione Albero

A: Without key shaft | Ohne Passfeder | Senza chiavetta
B: With key shaft | Mit Passfeder | Con sede chiavetta

Screw type | Spindeltyp | Vite tipo

R: Rolled screw with ball recirculating
Kugelrollspindel | Rullata a ricircolo di sfere
T: Trapezoidal screw | Trapez spindel | Vite trapezia
G: Grounded | Kugelgewinde | Vite rettificata